

## 25BY46L

### 典型应用领域:

微型打印机  
电子膨胀阀控制  
洁具

### Typical Applications:

Miniprinter  
Electrical Expansion Valve Control  
Sanitary Appliance



### 性能参数 Performance Parameters

电机尺寸 Motor Size	步进角 Step Angle	驱动方式 Drive Method	驱动电路 Drive Circuit	驱动电压 Drive Voltage	电流 Current /phase	线圈电阻 Coil Resistance /phase	驱动IC Drive IC	磁铁材质 Magnet material	绝缘电阻 Insulation Resistance	绝缘耐压 Dielectric Strength	绝缘等级 Class of Insulation	工作温度 Operating Temp	储存温度 Storage Temp	运行杂声 Operating Hum
25mm	24(15°/Step)	2-2 PHASE 2-2相	UNIPOLAR CONST.VOLT	24[V]	-	50[Ω]	SLA7024M Sanken	Nd-Fe-B bonded magnet	100M[Ω]MIN	AC 500[V]1[min]	CLASS E	-10[°C] ~50[°C]	-30[°C] ~80[°C]	20[%]RH ~90[%]RH
			BIPOLAR CHOPPER 双极	12[V]		30[Ω]	L297/298							

### 机械尺寸 Mechanical Dimensions:mm

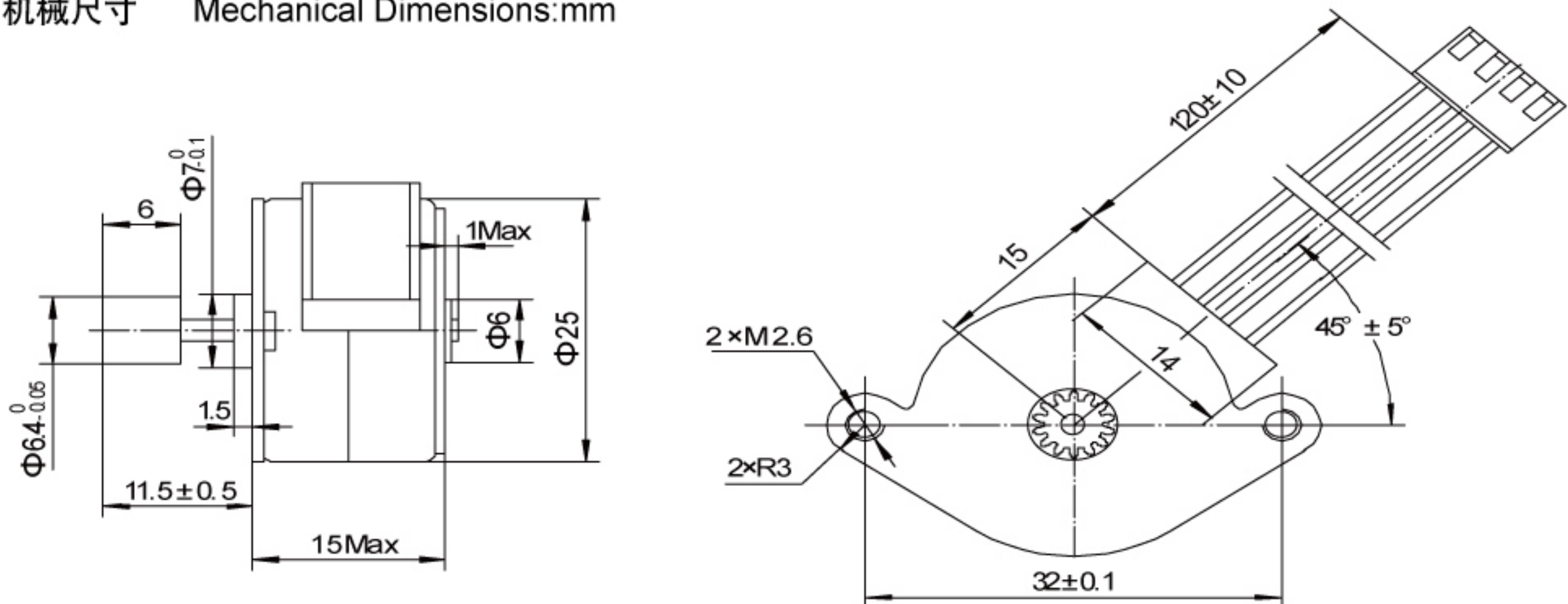

### 矩频曲线图 Frequency-torque characteristics

25BY46L UNIPOLAR CONST.VOLT(at24[V],50[Ω])

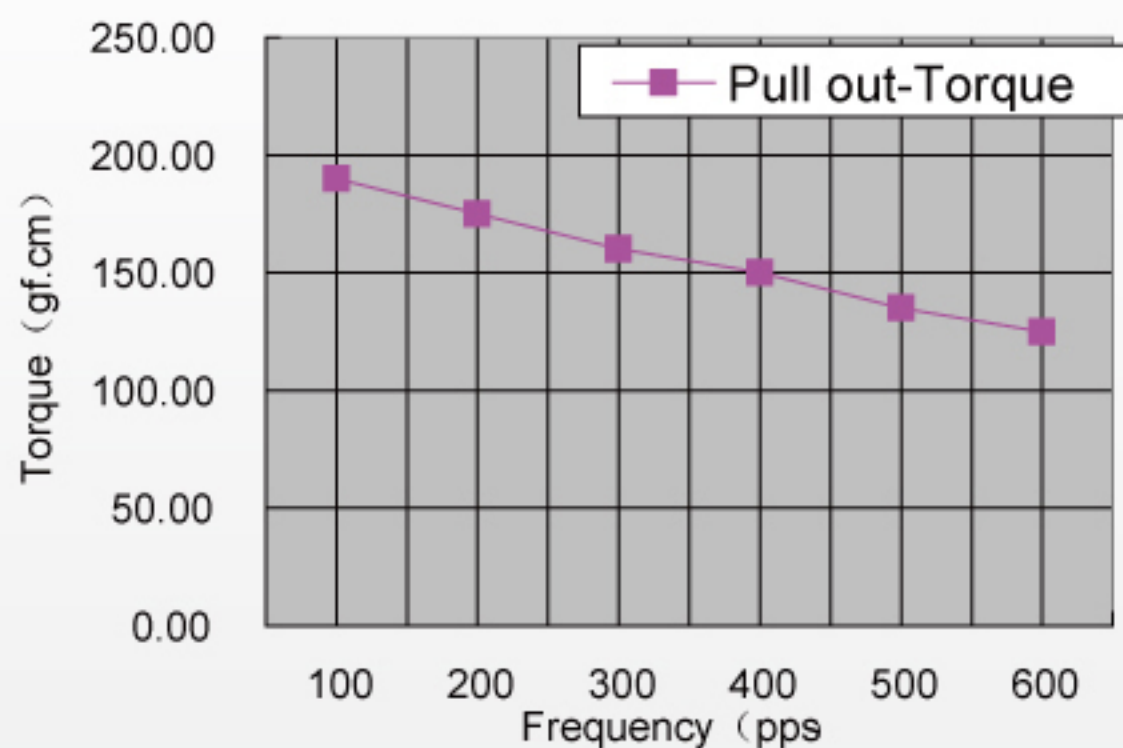

25BY46L BIPOLAR CHOPPER(at12[V],30[Ω])

