

25BY412L

典型应用领域:

- 微型打印机
- 电子膨胀阀控制
- 洁具

Typical Applications:

- Miniprinter
- Electrical Expansion Valve Control
- Sanitary Appliance



性能参数 Performance Parameters

电机尺寸 Motor Size	步进角 Step Angle	驱动方式 Drive Method	驱动电路 Drive Circuit	驱动电压 Drive Voltage	电流 Current /phase	线圈电阻 Coil Resistance /phase	驱动IC Drive IC	磁铁材质 Magnet material	绝缘电阻 Insulation Resistance	绝缘耐压 Dielectric Strength	绝缘等级 Class of Insulation	工作温度 Operating Temp	储存温度 Storage Temp	运行杂声 Operating Hum
25mm	48(7.5°/Step)	2-2 PHASE 2-2相	UNIPOLAR CONST.VOLT	5[V]	-	90[Ω]	L297/298	Nd-Fe-B bonded magnet	100M[Ω]MIN	AC 500[V]1[min]	CLASS E	-10[°C] ~50[°C]	-30[°C] ~80[°C]	20[%]RH ~90[%]RH
			BIPOLAR CHOPPER 双极	20[V]		90[Ω]	SLA7024M Sanken							

机械尺寸 Mechanical Dimensions:mm

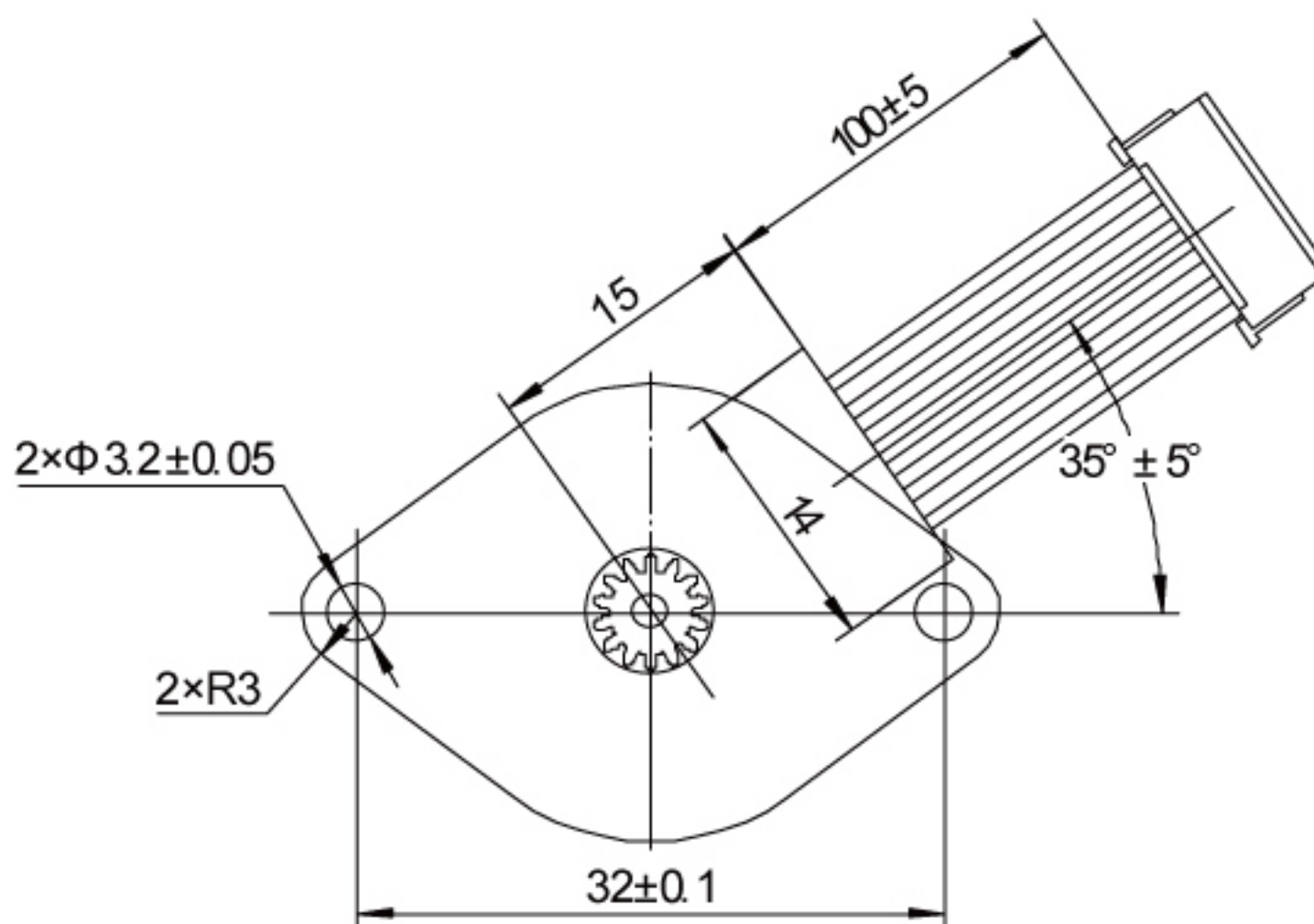
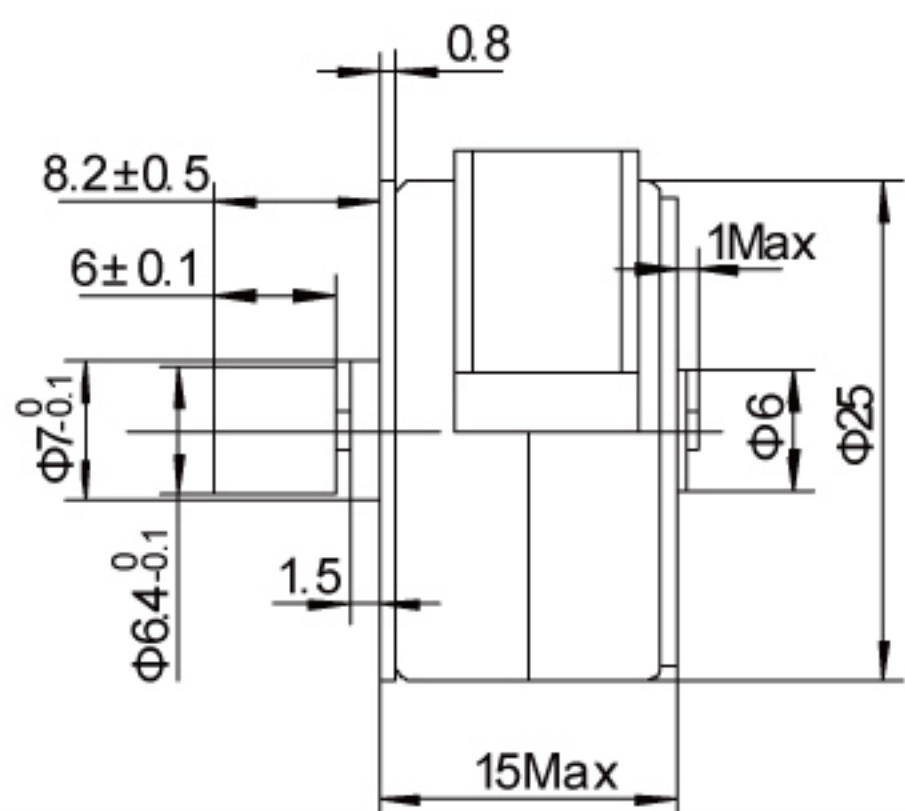

矩频曲线图 Frequency-torque characteristics

25BY412L UNIPOLAR CONST.VOLT(at20[V],90[Ω])

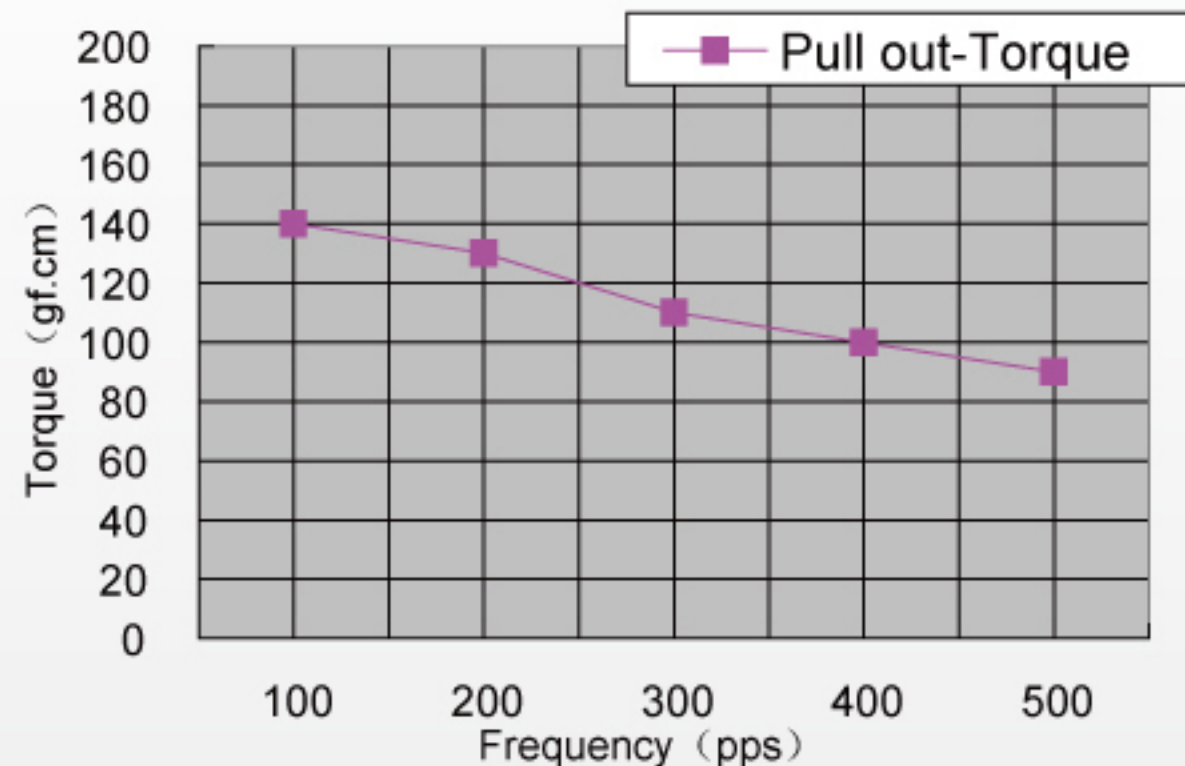

25BY412L BIPOLAR CHOPPER(at5[V],50[Ω])

