

42BY412S

典型应用领域:

- 办公自动化
- 针式打印机
- 热敏打印机
- 复印机
- 传真机
- 扫描仪
- 家用电器
- 洁具

Typical Applications:

- OA
- Stylus Printer
- Thermal Printer
- Copycat
- Fax Machine
- Scanner
- Home Appliances
- Sanitary Appliance



性能参数 Performance Parameters

电机尺寸 Motor Size	步进角 Step Angle	驱动方式 Drive Method	驱动电路 Drive Circuit	驱动电压 Drive Voltage	电流 Current /phase	线圈电阻 Coil Resistance /phase	驱动IC Drive IC	磁铁材质 Magnet material	绝缘电阻 Insulation Resistance	绝缘耐压 Dielectric Strength	绝缘等级 Class of Insulation	工作温度 Operating Temp	储存温度 Storage Temp	运行杂声 Operating Hum
42mm	48(7.5°/Step)	2-2 PHASE 2-2相	UNIPOLAR CONST.VOLT	12[V]	400[mA]	100[Ω]	SLA7024M Sanken	Nd-Fe-B bonded magnet	100M[Ω]MIN	AC 500[V]1[min]	CLASS E	-10[°C] ~50[°C]	-30[°C] ~80[°C]	20[%]RH ~90[%]RH
		1-2 PHASE 1-2相	BIPOLAR CHOPPER 双极	34[V]	900[mA]	6[Ω]	L297/298							

机械尺寸 Mechanical Dimensions:mm

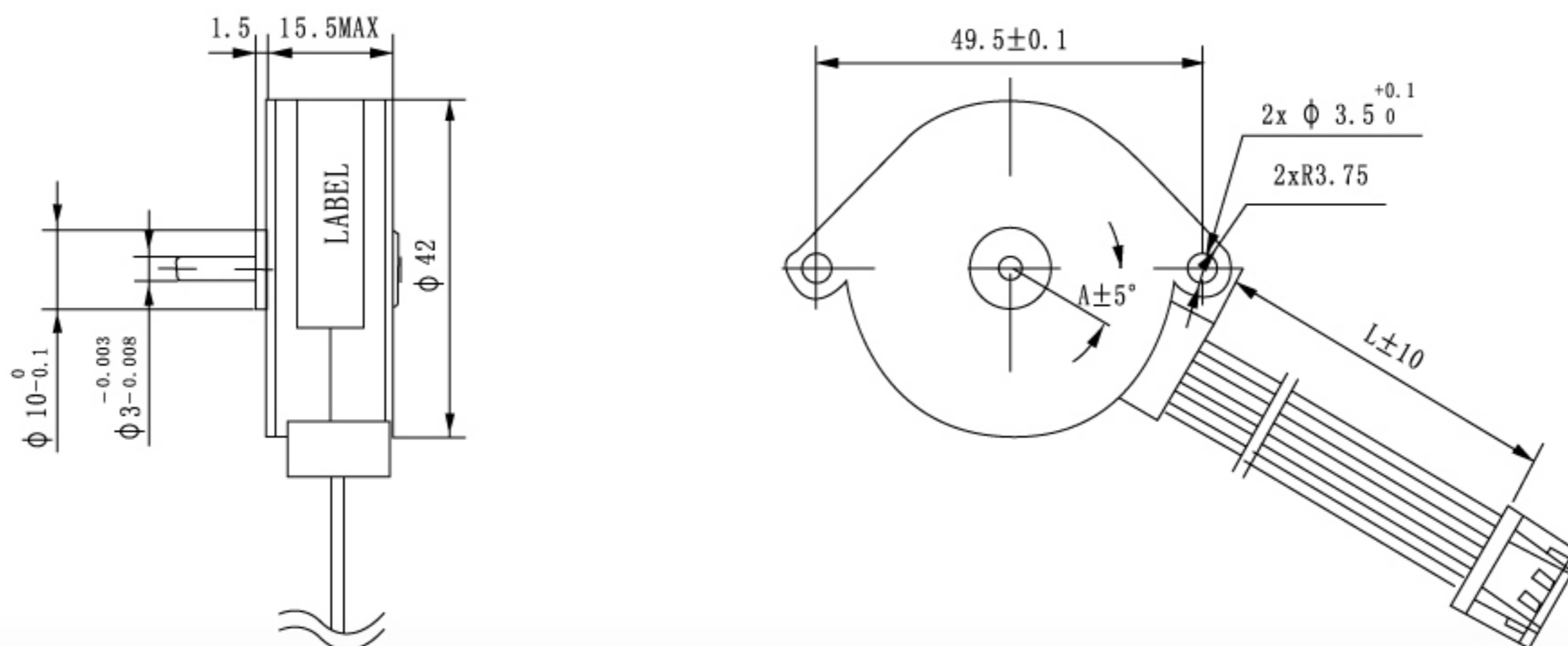

矩频曲线图 Frequency-torque characteristics

42BY412S BIPOLAR CHOPPER(at24[V],16[Ω],400[mA])

