

IG-08

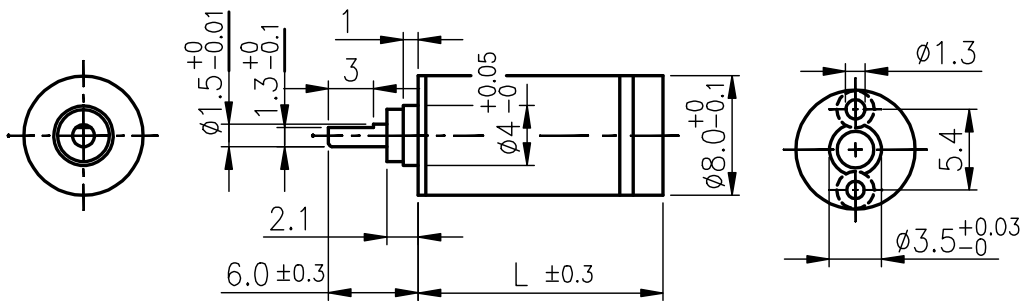

外殼材質 Housing material	金屬 metal	背隙 (無負荷時) Backlash, at no-load	≤ 3°
輸出軸承型式 Bearing at output		含油軸承 Sleeve bearings	
徑向負荷 Radial load (5mm from flange)		≤ 80 gf	
軸向負荷 Shaft axial load		≤ 100 gf	
主軸最大承受壓入力 Shaft press fit force, max.		≤ 500 gf	
徑向間隙 Radial play of shaft		≤ 0.05 mm	
軸向間隙 Thrust play of shaft		≤ 0.2 mm	

外形尺寸 APPEARANCE SIZE



scale: 2:1

馬達齒輪型式 / PINION SPECIFICATIONS

模數 Module	0.16
齒數 No. of teeth	12
壓力角 Pressure angle	20°
孔徑 Hole diameter	∅0.99
減速比 Reduction ratio	全種通用 Practicable

馬達裝卸方法 / MOTOR INSTALLATION

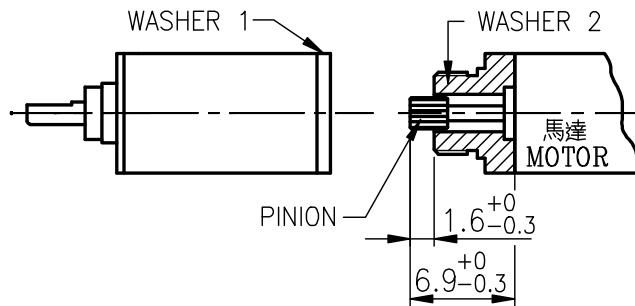

標準減速比型式 / GEARBOXES SPECIFICATIONS

減速比 Reduction ratio	精確減速比 Exact reduction ratio	定格容許扭力 Rated tolerance torque	瞬間容許扭力 Max momentary tolerance torque	效率 Efficiency	L	重量 (含油軸承) Weight (g) Sleeve bearings
1/4	4	50 gf-cm Max.	150 gf-cm	85%	11.6	2.9
1/16	16	100 gf-cm Max.	300 gf-cm	75%	14.3	3.8
1/64	64	200 gf-cm Max.	600 gf-cm	65%	17.0	4.6
1/256	256	300 gf-cm Max.	900 gf-cm	55%	19.7	5.4
1/1024	1024	350 gf-cm Max.	1050 gf-cm	45%	22.4	6.3
1/4096	4096	400 gf-cm Max.	1200 gf-cm	40%	25.1	7.1

★ 使用相對溼度: 20%~85%RH ★ 使用溫度範圍: -10°C~+60°C
Operating relative humidity Operating temperature range