

IG-60W

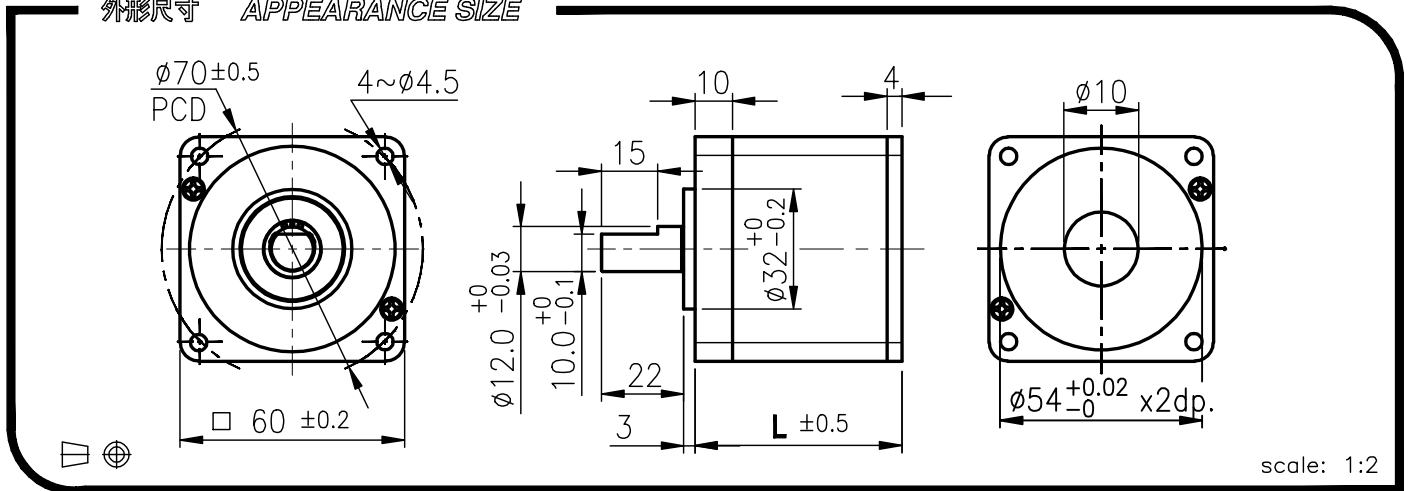

外殼材質 Housing material	金屬 metal	背隙 (無負荷時) Backlash, at no-load	≤ 3°
輸出軸承型式 Bearing at output	滾珠軸承 Ball bearings		
徑向負荷 Radial load (10mm from flange)	≤ 20 kgf		
軸向負荷 Shaft axial load	≤ 10 kgf		
主軸最大承受壓力 Shaft press fit force, max.	≤ 30 kgf		
徑向間隙 Radial play of shaft	≤ 0.08 mm		
軸向間隙 Thrust play of shaft	≤ 0.4 mm		

外形尺寸 APPEARANCE SIZE



馬達齒輪型式 / PINION SPECIFICATIONS

模數 Module	1.0		
齒數 No. of teeth	12	14	16
壓力角 Pressure angle	20°		
孔徑 Hole diameter	$\phi 6 \times 4.5$	$\phi 8 \times 6$	
減速比 Reduction ratio	1/4, 1/15, 1/19 1/53, 1/66, 1/81 1/113, 1/230, 1/285 1/353, 1/488 1/546, 1/676	1/100	1/3 1/12 1/43 1/150

馬達裝卸方法 / MOTOR INSTALLATION

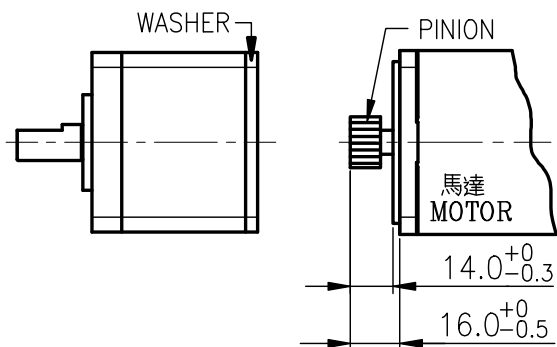

標準減速比型式 / GEARBOXES SPECIFICATIONS

★ 使用相對溼度: 20%~85%RH ★ 使用溫度範圍: -10°C~+60°C
Operating relative humidity Operating temperature range

減速比 Reduction ratio	精確減速比 Exact reduction ratio	定格容許扭力 Rated tolerance torque	瞬間容許扭力 Max momentary tolerance torque	效率 Efficiency	L	重量 Weight (g)
1/3, 1/4	3 1/2, 4 1/3	15 kgf-cm Max.	45 kgf-cm	80%	43.3	510
1/12, 1/15	12 1/4, 15 1/6	50 kgf-cm Max.	150 kgf-cm	70%	58.8	730
1/19	18 7/9	50 kgf-cm Max.	150 kgf-cm	70%	58.8	730
1/43, 1/53, 1/66	42 7/8, 53 1/12, 65 13/18	100 kgf-cm Max.	300 kgf-cm	60%	74.3	980
1/81, 1/100	81 10/27, 100 2/7	100 kgf-cm Max.	300 kgf-cm	60%	74.3	980
1/113	112 2/3	100 kgf-cm Max.	300 kgf-cm	60%	74.3	980
1/150	150 1/16	100 kgf-cm Max.	300 kgf-cm	50%	89.8	1210
1/230, 1/285	230 1/36, 284 43/54	100 kgf-cm Max.	300 kgf-cm	50%	89.8	1210
1/353, 1/488	352 49/81, 488 2/9	100 kgf-cm Max.	300 kgf-cm	50%	89.8	1210
1/546, 1/676	546, 676	100 kgf-cm Max.	300 kgf-cm	50%	89.8	1210

IG-60WGM

01&02 TYPE



REDUCTION RATIO	L	REDUCTION RATIO	L
1/3~1/4	43.3	1/150~1/676	89.8
1/12~1/19	58.8		
1/43~1/113	74.3		

外形尺寸 APPEARANCE SIZE

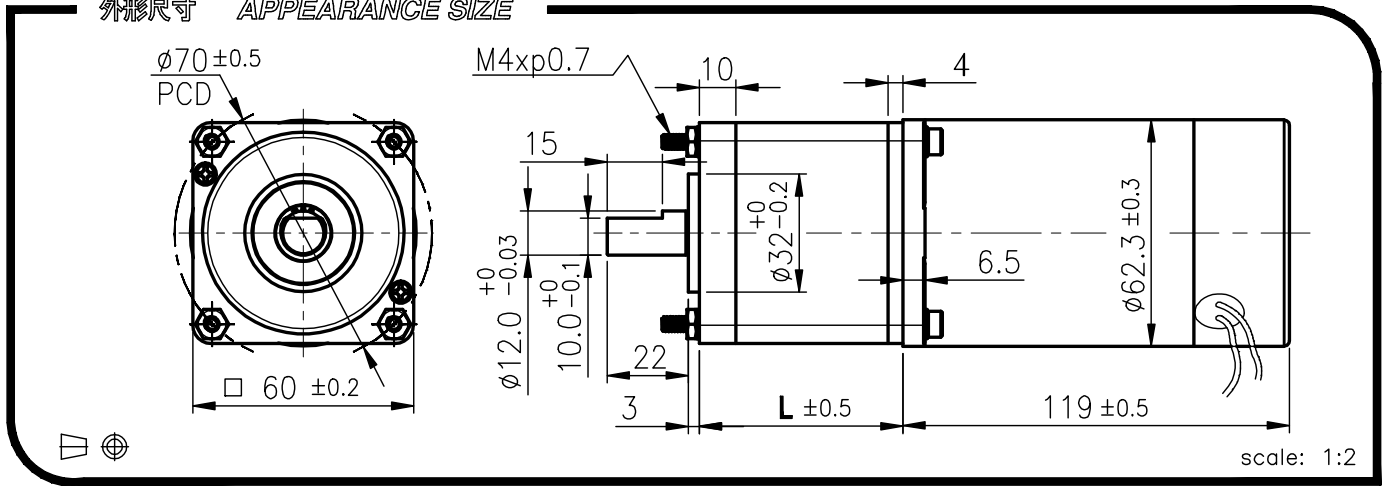

scale: 1:2

GEARED MOTOR TORQUE/SPEED

	減速比 Reduction ratio	1/3	1/4	1/12	1/15	1/19	1/43	1/53	1/66	1/81	1/100	1/113	1/150	1/230	1/285	1/353	1/488	1/546	1/676
		12V	1.9	2.4	6.0	7.4	9.0	18	22	27	34	42	47	52	80	99	100	100	100
	定格扭力(Kg-cm) Rated torque	1350	1090	385	310	250	110	89	72	58	47	42	31.5	20.5	16.5	13.6	9.8	8.9	7.2
	定格回轉數(rpm) Rated speed	2.7	3.4	8.5	10.5	13	25	31	39	48	60	67	75	100	100	100	100	100	100
24V	定格扭力(Kg-cm) Rated torque	1380	1100	390	310	255	110	90	73	59	48	42	32	21	17.1	13.8	10	9.0	7.3
	定格回轉數(rpm) Rated speed																		

馬達單體型式 / MOTOR DATA

定格電壓 Rated volt (V)	定格扭力 Rated torque (g-cm)	定格回轉數 Rated speed (rpm)	定格電流 Rated current (mA)	無負荷回轉數 No load speed (rpm)	無負荷電流 No load current (mA)	定格出力 Rated output (W)	重量 Weight (g)
12	700	4760	≤ 3300	5100	≤ 1500	34.2	1150
24	1000	4830	≤ 2400	5100	≤ 800	49.6	1150

馬達單體特性圖 / MOTOR CHARACTERISTICS

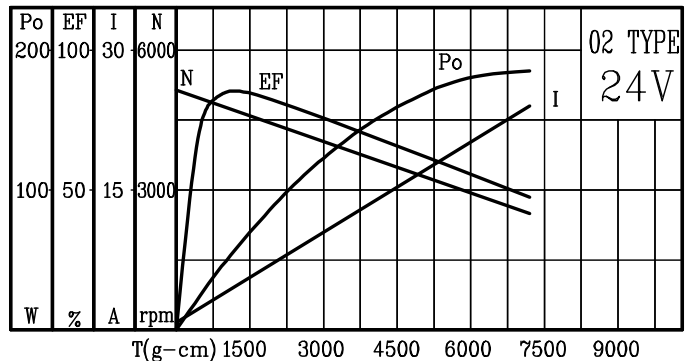
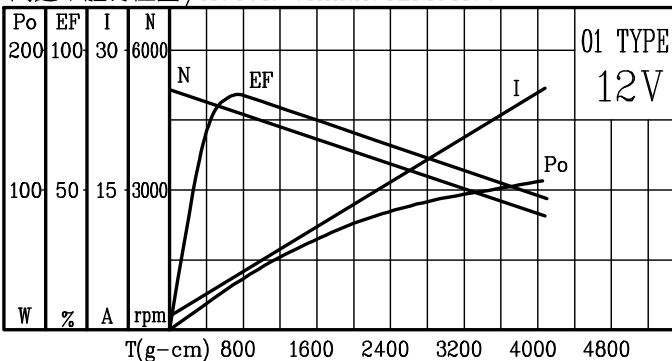

IG-60WGM 41 TYPE



REDUCTION RATIO	L	REDUCTION RATIO	L
1/3~1/4	43.3	1/150~1/676	89.8
1/12~1/19	58.8		
1/43~1/113	74.3		

外形尺寸 APPEARANCE SIZE

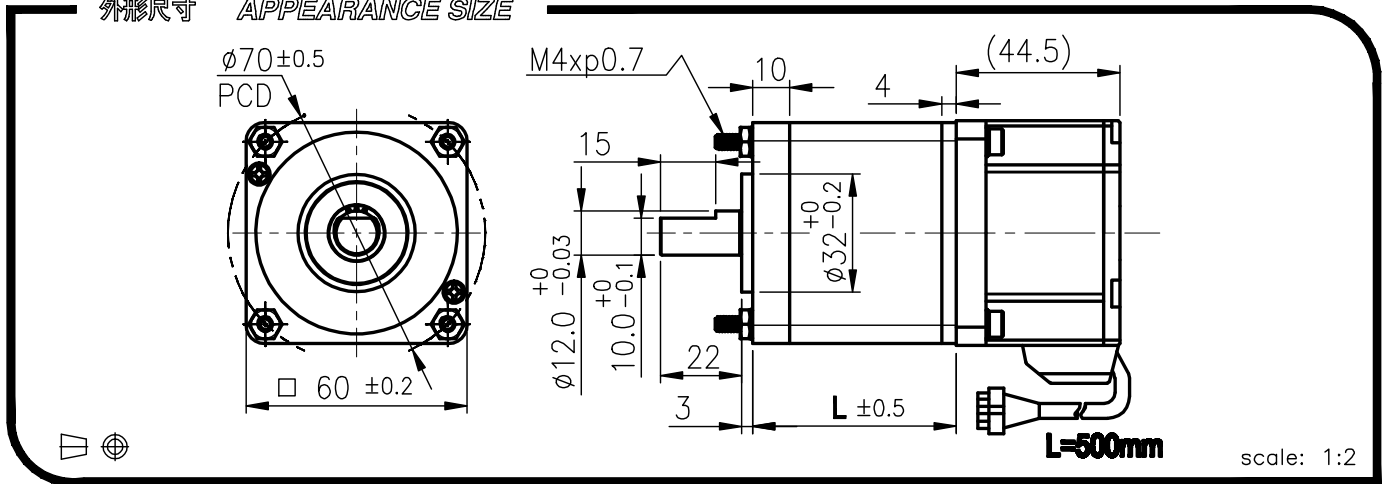

GEARED MOTOR TORQUE/SPEED

	減速比 Reduction ratio	1/3	1/4	1/12	1/15	1/19	1/43	1/53	1/66	1/81	1/100	1/113	1/150	1/230	1/285	1/353	1/488	1/546	1/676		
24V	定格扭力(Kg-cm) Rated torque	3.3	4.1	10	12.6	15.8	30.8	38	47.5	58	72	81	90	80	100	100	100	100	100		
	定格回轉數(rpm) Rated speed	714	576	204	164	133	58	47	38	30.7	25	22.1	16.6	10.8	8.7	7.1	5.1	4.5	3.6		

馬達單體型式 / MOTOR DATA

定格電壓 Rated volt (V)	定格扭力 Rated torque (g-cm)	定格回轉數 Rated speed (rpm)	定格電流 Rated current (mA)	無負荷回轉數 No load speed (rpm)	無負荷電流 No load current (mA)	定格出力 Rated output (W)	重量 Weight (g)
24	1200	2500	≤ 1800	3000	≤ 400	30.81	500
啓動扭力 Start torque (g-cm)	絕緣耐壓 Insulation voltage	絕緣阻抗 Insulation resistance	絕緣等級 Insulation class	使用相對濕度 Operating relative humidity	使用溫度範圍 Operating temperature range		
1500	60HZ AC500V	100M Ω DC500V	A class(105°C)	20%~85%RH	0~+50°C		

馬達單體特性圖 / MOTOR CHARACTERISTICS

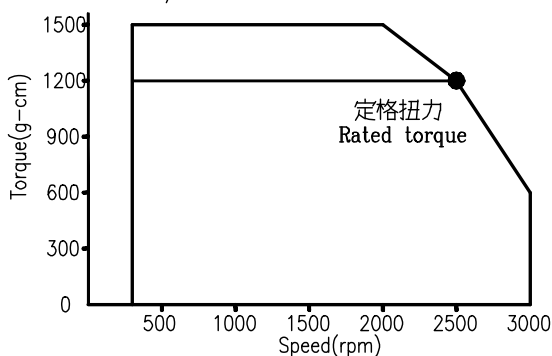

搭配之驅動器型式 / CONNECTED WITH MOTOR DRIVER

型號 Type	KBM6030KA
輸入電壓 Input voltage	DC 24V±10%
速度控制範圍 Speed control range	300~3000 rpm
速度設定方式 Speed control way	1. 內部速度設定 Internal control 2. 外部速度設定 External speed control 3. 外部直流電壓控制 (DC 0~5V) External voltage control (DC 0~5V)