

IG-70W

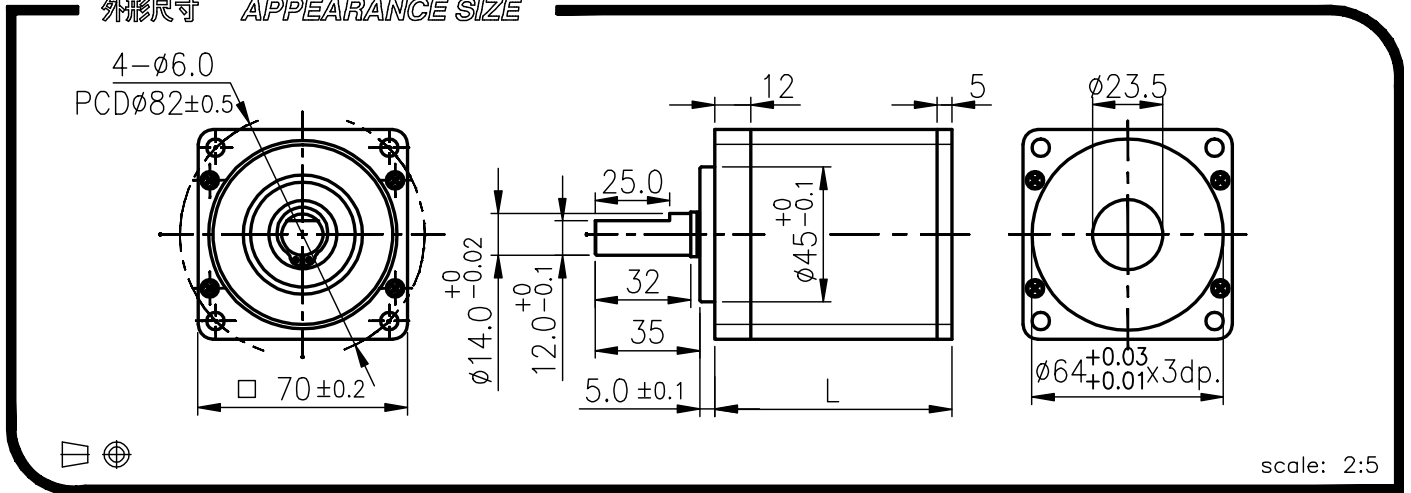

外殼材質 Housing material	金屬 metal	背隙 (無負荷時) Backlash, at no-load	≤ 3°
輸出軸承型式 Bearing at output	滾珠軸承 Ball bearings		
徑向負荷 Radial load (10mm from flange)	≤ 25 kgf		
軸向負荷 Shaft axial load	≤ 10 kgf		
主軸最大承受壓入力 Shaft press fit force, max.	≤ 50 kgf		
徑向間隙 Radial play of shaft	≤ 0.08 mm		
軸向間隙 Thrust play of shaft	≤ 0.4 mm		

外形尺寸 APPEARANCE SIZE



馬達齒輪型式 / PINION SPECIFICATIONS

模數 Module	1.0			
齒數 No. of teeth	13	14	18	20
壓力角 Pressure angle	20°			
孔徑 Hole diameter	Ø6x4.5		Ø8 x 6	
減速比 Reduction ratio	1/102, 1/126 1/242, 1/300 1/363, 1/493 1/611,	1/16, 1/20 1/60, 1/75 1/91, 1/414 1/543,	1/13 1/50 1/189	1/4

馬達裝卸方法 / MOTOR INSTALLATION

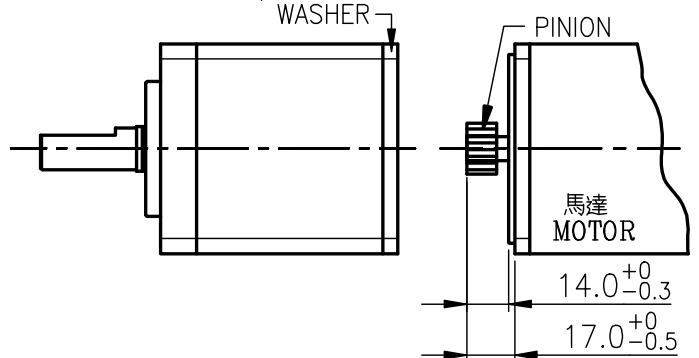

★ 使用相對溼度: 20%~85%RH ★ 使用溫度範圍: -10°C~+60°C
Operating relative humidity Operating temperature range

標準減速比型式 / GEARBOXES SPECIFICATIONS

減速比 Reduction ratio	精確減速比 Exact reduction ratio	定格容許扭力 Rated tolerance torque	瞬間容許扭力 Max momentary tolerance torque	效率 Efficiency	L	重量 Weight (g)
1/4	3 1/2	15 kgf-cm Max.	45 kgf-cm	80%	47.3	780
1/13, 1/16	13 2/9, 16	70 kgf-cm Max.	210 kgf-cm	70%	63.8	1110
1/20	19 17/21	70 kgf-cm Max.	210 kgf-cm	70%	63.8	1110
1/50, 1/60, 1/75	49 77/81, 60 4/9, 74 158/189	125 kgf-cm Max.	375 kgf-cm	60%	80.3	1440
1/91, 1/102	90 82/147, 101 10/13	125 kgf-cm Max.	375 kgf-cm	60%	80.3	1440
1/126	126	125 kgf-cm Max.	375 kgf-cm	60%	80.3	1440
1/189, 1/242	188 512/729, 242 8/117	125 kgf-cm Max.	375 kgf-cm	50%	96.8	1780
1/300, 1/363	299 19/27, 362 2/3	125 kgf-cm Max.	375 kgf-cm	50%	96.8	1780
1/414	413 1007/1029	125 kgf-cm Max.	375 kgf-cm	50%	96.8	1780
1/493, 1/543	493 32/169, 543 51/147	125 kgf-cm Max.	375 kgf-cm	50%	96.8	1780
1/611	610 24/39	125 kgf-cm Max.	375 kgf-cm	50%	96.8	1780

IG-70WGM

01&02 TYPE



REDUCTION RATIO	L	REDUCTION RATIO	L
1/4	47.3	1/189~1/611	96.8
1/13~1/20	63.8		
1/50~1/126	80.3		

外形尺寸 APPEARANCE SIZE

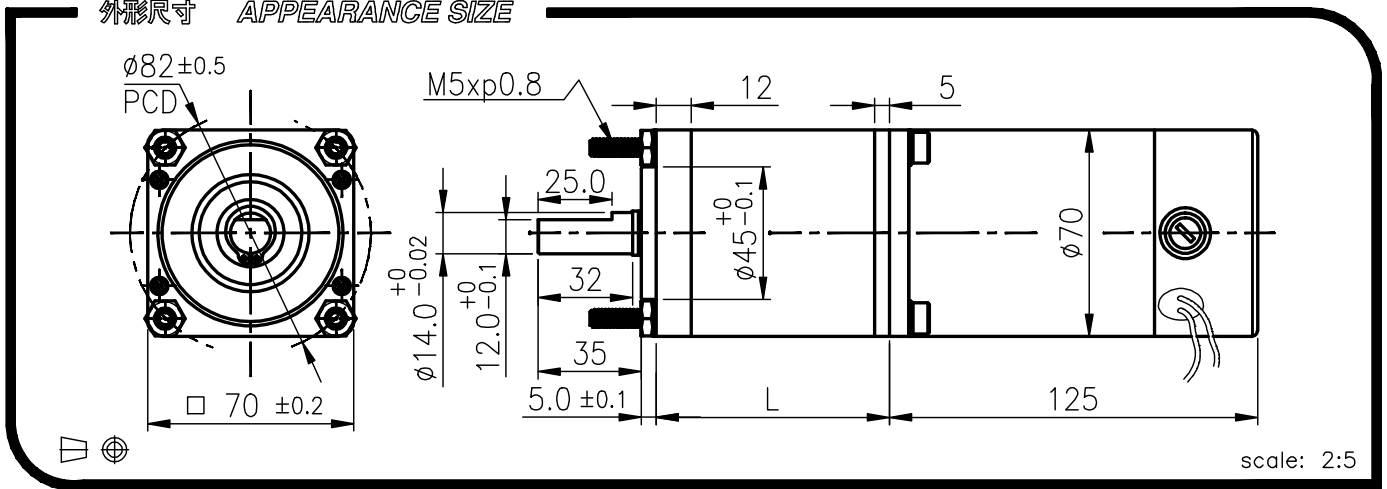

GEARED MOTOR TORQUE/SPEED

	減速比 Reduction ratio	1/4	1/13	1/16	1/20	1/50	1/60	1/75	1/91	1/102	1/126	1/189	1/242	1/300	1/363	1/414	1/493	1/543	1/611	
		12V	4.2	13.8	16.8	20.4	44.9	54	67	81	91	113	125	125	125	125	125	125	125	
	定格扭力(Kg-cm) Rated torque																			
	定格回轉數(rpm) Rated speed	510	135	112	90.9	36	29.7	24	19.7	17.6	14.2	9.5	7.5	6.2	5.1	4.4	3.7	3.4	3.0	
24V	7	23.1	28	34.6	74.9	90.6	112	125	125	125	125	125	125	125	125	125	125	125	125	
	定格扭力(Kg-cm) Rated torque																			
	定格回轉數(rpm) Rated speed	510	135	112	90.9	36	29.7	24	19.8	17.7	14.3	9.6	7.6	6.3	5.2	4.5	3.8	3.5	3.1	

馬達單體型式 / MOTOR DATA

定格電壓 Rated volt (V)	定格扭力 Rated torque (g-cm)	定格回轉數 Rated speed (rpm)	定格電流 Rated current (mA)	無負荷回轉數 No load speed (rpm)	無負荷電流 No load current (mA)	定格出力 Rated output (W)	重量 Weight (g)
12	1500	1800	≤ 3000	2000	≤ 800	27.7	1650
24	2500	1800	≤ 2500	2000	≤ 400	46.2	1650

馬達單體特性圖 / MOTOR CHARACTERISTICS

