

# RA-15

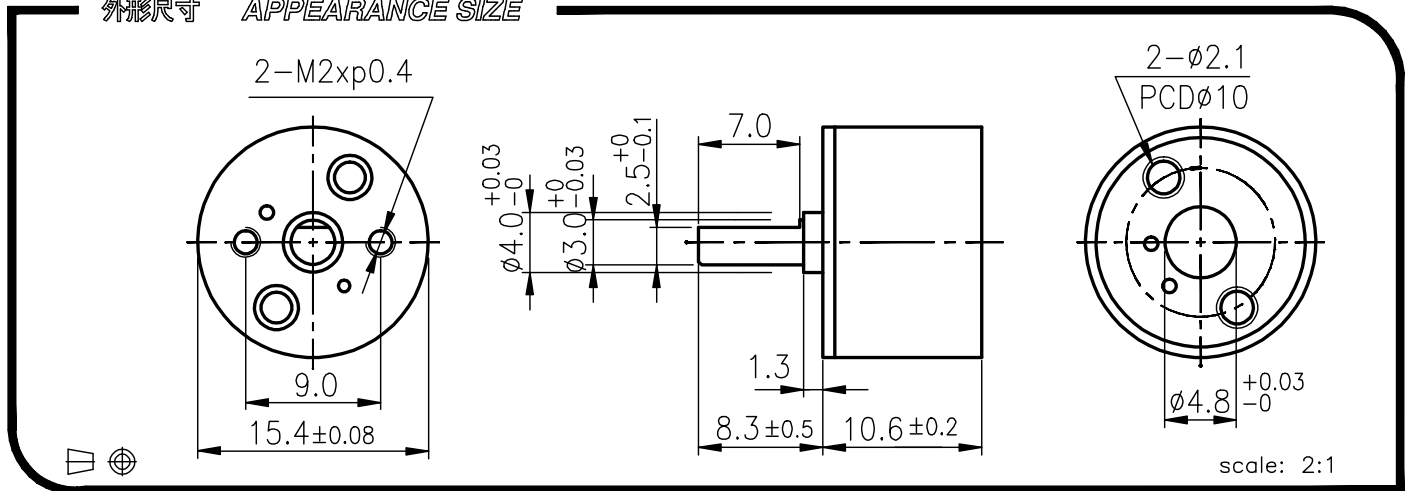

外殼材質 Housing material	塑膠 Plastic	背隙 (無負荷時) Backlash, at no-load	≤ 1.5°
輸出軸承型式 Bearing at output	---		
徑向負荷 Radial load (5mm from flange)	≤ 0.4kgf		
軸向負荷 Shaft axial load	≤ 0.2 kgf		
主軸最大承受壓入力 Shaft press fit force, max.	≤ 2 kgf		
徑向間隙 Radial play of shaft	≤ 0.06 mm		
軸向間隙 Thrust play of shaft	≤ 0.2 mm		

外形尺寸 APPEARANCE SIZE



馬達齒輪型式 / PINION SPECIFICATIONS

馬達裝卸方法 / MOTOR INSTALLATION

模數 Module	0.15		
齒數 No. of teeth	14	16	18
壓力角 Pressure angle	20°		
孔徑 Hole diameter	∅1.49		
減速比 Reduction ratio	1/10, 1/34 1/105 1/360	1/21, 1/59 1/75, 1/203 1/257, 1/294	1/146

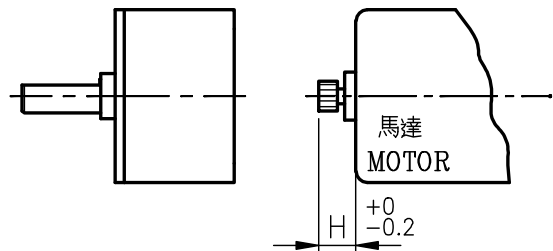

標準減速比型式 / GEARBOXES SPECIFICATIONS

★ 使用相對溼度: 20%~85%RH    ★ 使用溫度範圍: -10°C~+60°C  
Operating relative humidity    Operating temperature range

減速比 Reduction ratio	精確減速比 Exact reduction ratio	定格容許扭力 Rated tolerance torque	瞬間容許扭力 Max momentary tolerance torque	效率 Efficiency	H	重量 Weight ( g )
1/10	9 20/21	0.2 kgf-cm Max.	0.6 kgf-cm	81%	3.4	6.0
1/21	21 147/400	0.3 kgf-cm Max.	0.9 kgf-cm	73%	2.4	6.0
1/34	34 34/189	0.3 kgf-cm Max.	0.9 kgf-cm	73%	2.4	6.0
1/59	59 97/208	0.5 kgf-cm Max.	1.5 kgf-cm	66%	3.4	6.0
1/75	75 1137/2600	0.5 kgf-cm Max.	1.5 kgf-cm	66%	3.4	6.0
1/105	104 332/455	0.8 kgf-cm Max.	2.4 kgf-cm	66%	3.4	6.0
1/146	146 3/10	0.8 kgf-cm Max.	2.4 kgf-cm	59%	2.4	6.0
1/203	202 71/78	1.0 kgf-cm Max.	3.0 kgf-cm	59%	2.4	6.0
1/257	256 191/325	1.0 kgf-cm Max.	3.0 kgf-cm	59%	2.4	6.0
1/294	293 431/585	1.0 kgf-cm Max.	3.0 kgf-cm	59%	2.4	6.0
1/360	359 185/273	1.0 kgf-cm Max.	3.0 kgf-cm	59%	2.4	6.0

# RA-15GM

## 01&02 TYPE



外形尺寸 APPEARANCE SIZE

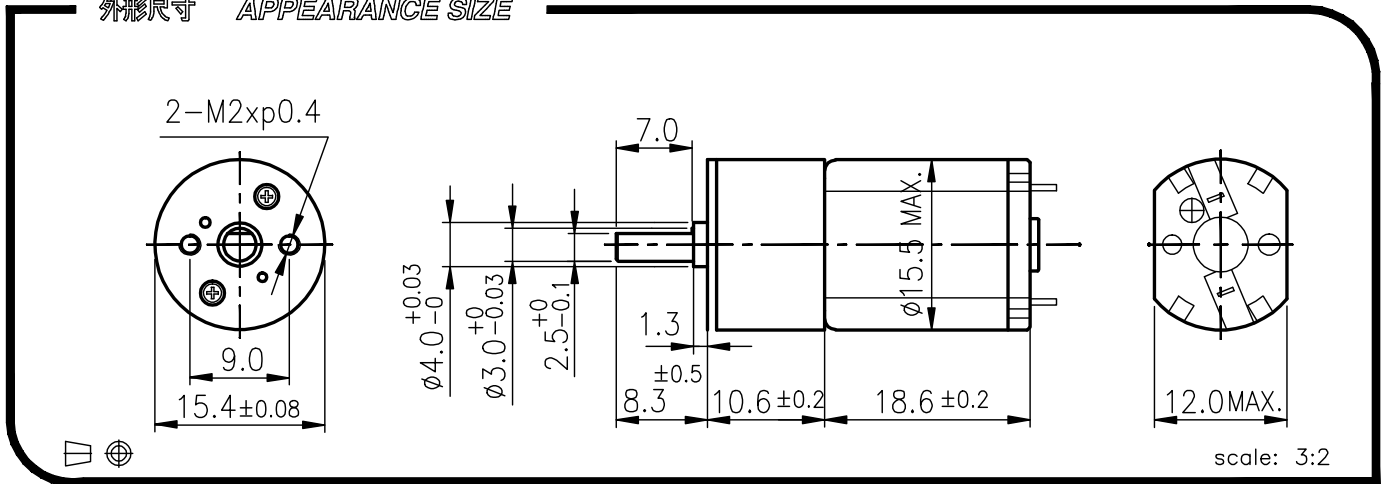

GEARED MOTOR TORQUE/SPEED

	減速比 Reduction ratio	1	1	1	1	1	1	1	1	1	1							
		10	21	34	59	75	105	146	203	257	294	360						
6V	定格扭力(g-cm) Rated torque	30	60	100	155	200	270	340	470	600	690	840						
	定格回轉數(rpm) Rated speed	950	445	270	160	125	91	65	47	37	32	26						
12V	定格扭力(g-cm) Rated torque	35	70	110	175	220	310	380	530	680	780	950						
	定格回轉數(rpm) Rated speed	870	400	255	145	116	83	59	43	34	29	24						

馬達單體型式 / MOTOR DATA

定格電壓 Rated volt (V)	定格扭力 Rated torque (g-cm)	定格回轉數 Rated speed (rpm)	定格電流 Rated current (mA)	無負荷回轉數 No load speed (rpm)	無負荷電流 No load current (mA)	定格出力 Rated output (W)	重量 Weight (g)
6	4.0	9600	≤ 140	11500	≤ 50	0.39	10
12	4.5	8750	≤ 100	11700	≤ 30	0.4	10

馬達單體特性圖 / MOTOR CHARACTERISTICS

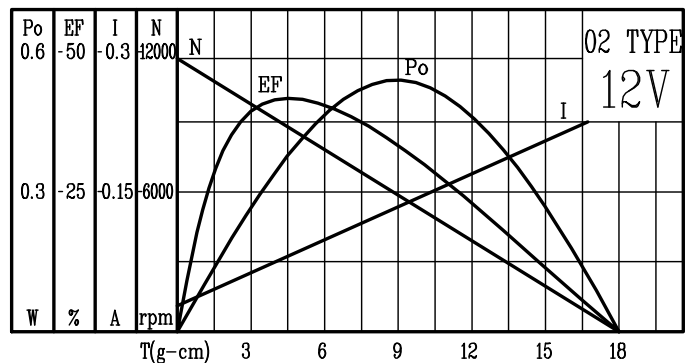
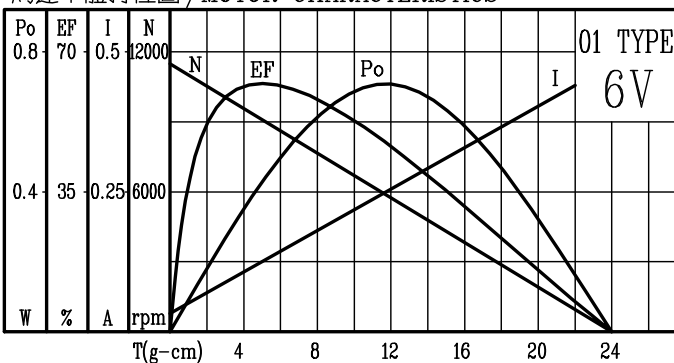

# RA-15GM

## 03&04 TYPE



外形尺寸 APPEARANCE SIZE

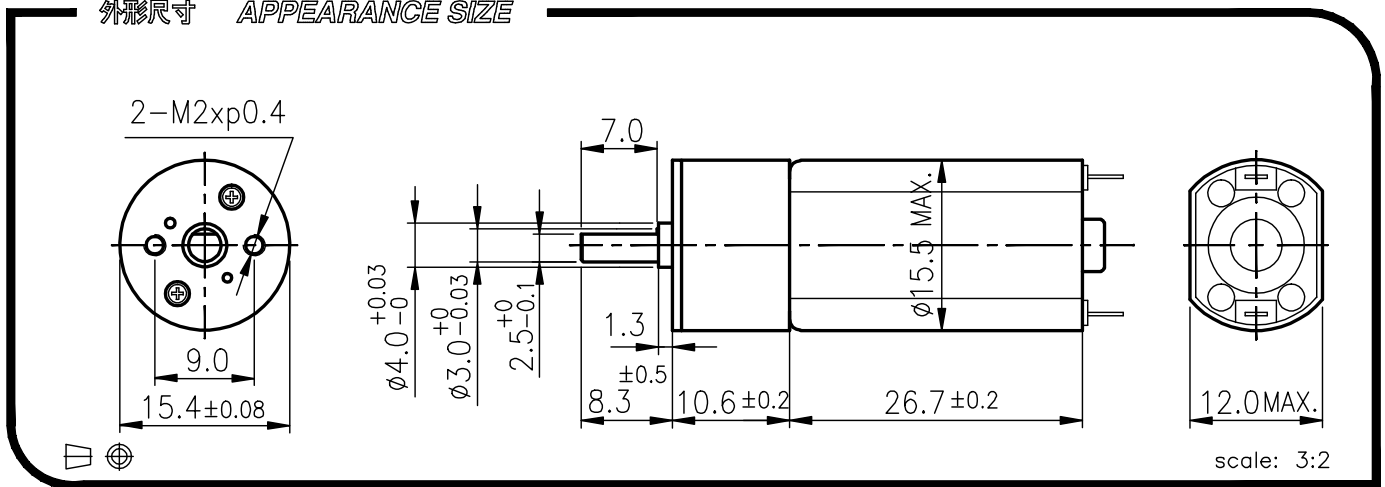

GEARED MOTOR TORQUE/SPEED

減速比 Reduction ratio		1/10	1/21	1/34	1/59	1/75	1/105	1/146	1/203	1/257	1/294	1/360				
6V	定格扭力(g-cm) Rated torque	55	110	180	285	365	510	635	880	1000	1000	1000				
	定格回轉數(rpm) Rated speed	650	300	190	110	86	62	44	32	25	23	19				
12V	定格扭力(g-cm) Rated torque	45	90	150	235	300	420	520	730	920	1000	1000				
	定格回轉數(rpm) Rated speed	620	290	180	100	82	59	42	30	24	21	18				

馬達單體型式 / MOTOR DATA

定格電壓 Rated volt (V)	定格扭力 Rated torque (g-cm)	定格回轉數 Rated speed (rpm)	定格電流 Rated current (mA)	無負荷回轉數 No load speed (rpm)	無負荷電流 No load current (mA)	定格出力 Rated output (W)	重量 Weight (g)
6	7.4	6550	≤ 160	8000	≤ 65	0.5	18
12	6.1	6200	≤ 85	8000	≤ 50	0.394	18

馬達單體特性圖 / MOTOR CHARACTERISTICS

