

# RA-37GM

## 07&09 TYPE



REDUCTION RATIO	L	REDUCTION RATIO	L
1/6	21.8	1/219~1/625	32.0
1/16~1/21	24.6	1/750~1/1875	34.5
1/31~1/69	27.1	1/2813~1/5625	37.0
1/75~1/188	29.5		

外形尺寸 APPEARANCE SIZE

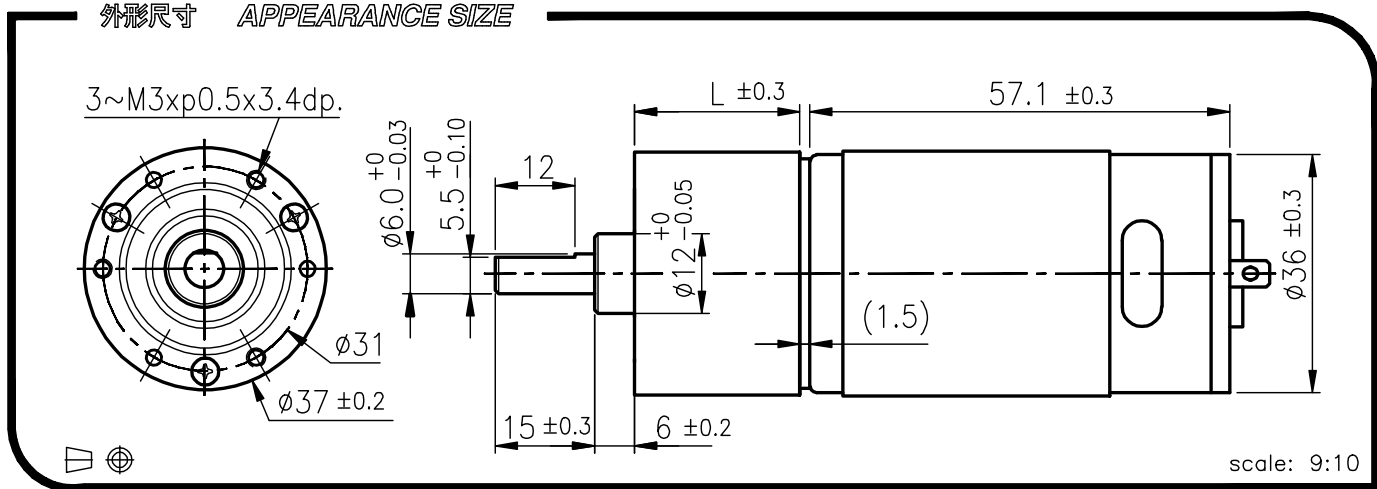

GEARED MOTOR TORQUE/SPEED

	減速比 Reduction ratio	1/6	1/16	1/21	1/31	1/56	1/75	1/104	1/125	1/156	1/188	1/219	1/250	1/312	1/469	1/625	1/750	1/938	1/1875	1/3750	1/5625	
		12V	1.0	2.0	2.0	3.0	4.0	5.0	5.0	6.0	6.0	6.0	6.0	6.0	6.0	6.0	6.0	6.0	6.0	6.0	6.0	6.0
	定格扭力(Kg-cm) Rated torque	1.0	2.0	2.0	3.0	4.0	5.0	5.0	6.0	6.0	6.0	6.0	6.0	6.0	6.0	6.0	6.0	6.0	6.0	6.0	6.0	6.0
	定格回轉數(rpm) Rated speed	795	330	250	172	95	72	54	45	37	31	26	23	18.7	12.5	9.3	7.8	6.2	3.2	1.5	1.0	
24V	1.0	2.0	2.0	3.0	4.0	5.0	5.0	6.0	6.0	6.0	6.0	6.0	6.0	6.0	6.0	6.0	6.0	6.0	6.0	6.0	6.0	6.0
	定格回轉數(rpm) Rated speed	805	338	260	175	97	73	55	46	38	32	26.8	23.4	18.8	12.5	9.5	7.8	6.3	3.2	1.6	1.0	

馬達單體型式 / MOTOR DATA

定格電壓 Rated volt (V)	定格扭力 Rated torque (g-cm)	定格回轉數 Rated speed (rpm)	定格電流 Rated current (mA)	無負荷回轉數 No load speed (rpm)	無負荷電流 No load current (mA)	定格出力 Rated output (W)	重量 Weight (g)
12	250	4930	≤ 1600	6000	≤ 250	12.80	220
24	240	5150	≤ 750	6000	≤ 130	12.70	220

馬達單體特性圖 / MOTOR CHARACTERISTICS

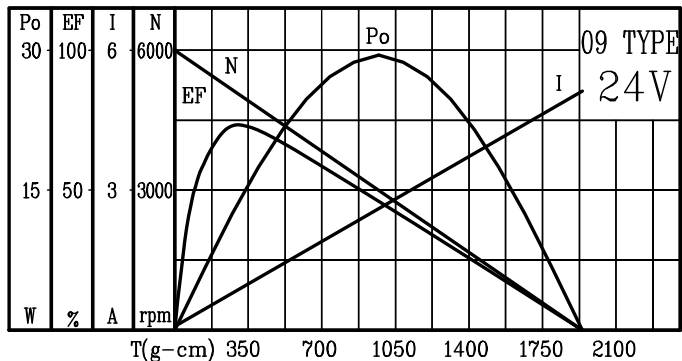
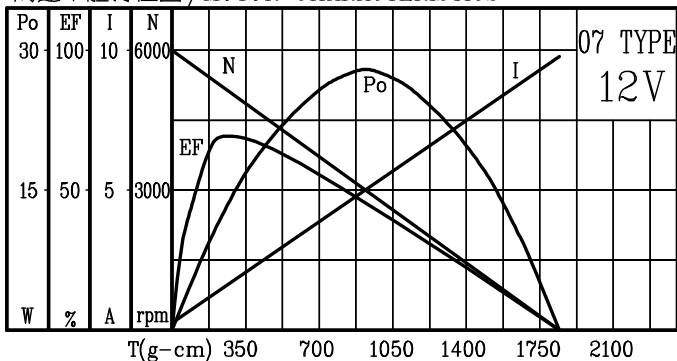

# RA-37GM

## 11&12 TYPE

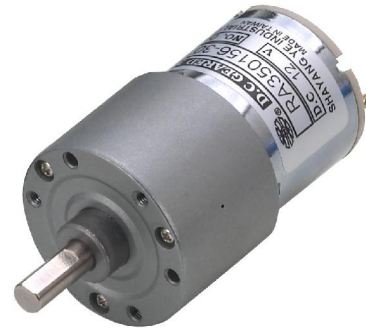

REDUCTION RATIO	L	REDUCTION RATIO	L
1/6	21.8	1/219~1/625	32.0
1/16~1/21	24.6	1/750~1/1875	34.5
1/31~1/69	27.1	1/2813~1/5625	37.0
1/75~1/188	29.5		

外形尺寸 APPEARANCE SIZE

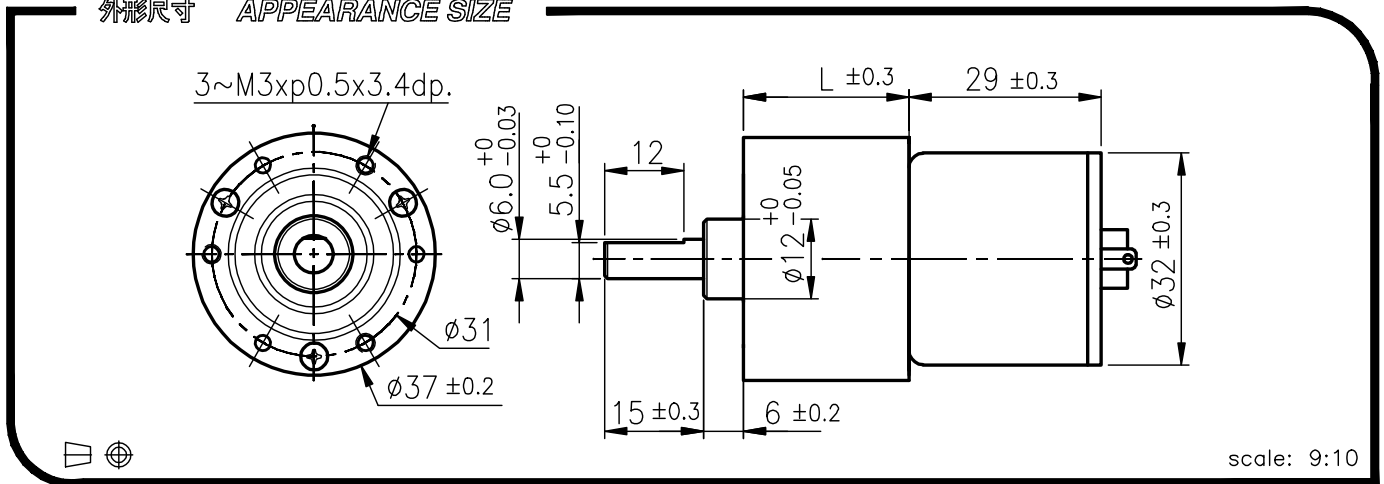

GEARED MOTOR TORQUE/SPEED

	減速比 Reduction ratio	1/6	1/16	1/21	1/31	1/56	1/75	1/104	1/125	1/156	1/188	1/219	1/250	1/312	1/469	1/625	1/750	1/938	1/1875	1/3750	1/5625	
		12V	0.3	0.68	0.9	1.25	2.2	2.6	3.6	4.4	5.5	6.0	6.0	6.0	6.0	6.0	6.0	6.0	6.0	6.0	6.0	6.0
	規格扭力(Kg-cm) Rated torque	800	310	245	155	90	67	49	41	33	28	24	21.5	17.6	12.3	9.1	7.8	6.3	3.2	1.6	1.0	
	規格回轉數(rpm) Rated speed	0.3	0.7	0.9	1.25	2.3	2.7	3.8	4.5	5.7	6.0	6.0	6.0	6.0	6.0	6.0	6.0	6.0	6.0	6.0	6.0	
24V	0.3	0.7	0.9	1.25	2.3	2.7	3.8	4.5	5.7	6.0	6.0	6.0	6.0	6.0	6.0	6.0	6.0	6.0	6.0	6.0	6.0	
	規格扭力(Kg-cm) Rated torque	780	308	240	150	87	65	48	40	32	27	23.5	21.5	17.5	12	9.0	7.8	6.2	3.2	1.6	1.0	
	規格回轉數(rpm) Rated speed																					

馬達單體型式 / MOTOR DATA

定格電壓 Rated volt (V)	定格扭力 Rated torque (g-cm)	定格回轉數 Rated speed (rpm)	定格電流 Rated current (mA)	無負荷回轉數 No load speed (rpm)	無負荷電流 No load current (mA)	定格出力 Rated output (W)	重量 Weight (g)
12	60	5100	≤ 470	6200	≤ 120	3.14	75
24	62	5000	≤ 210	6200	≤ 60	3.17	75

馬達單體特性圖 / MOTOR CHARACTERISTICS

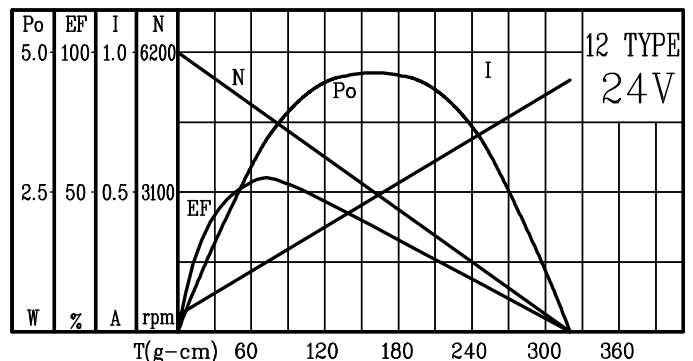
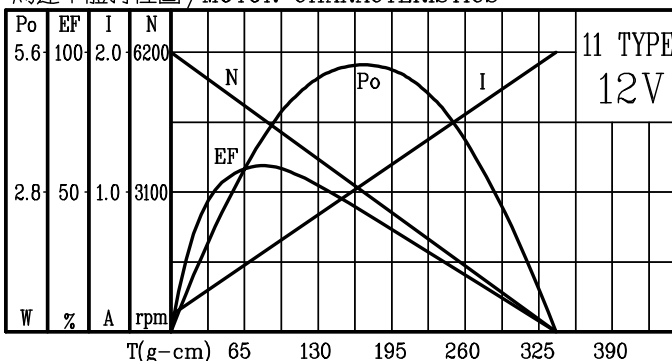

# RA-37GM

## 13&14 TYPE



REDUCTION RATIO	L	REDUCTION RATIO	L
1/6	21.8	1/219~1/625	32.0
1/16~1/21	24.6	1/750~1/1875	34.5
1/31~1/69	27.1	1/2813~1/5625	37.0
1/75~1/188	29.5		

外形尺寸 APPEARANCE SIZE

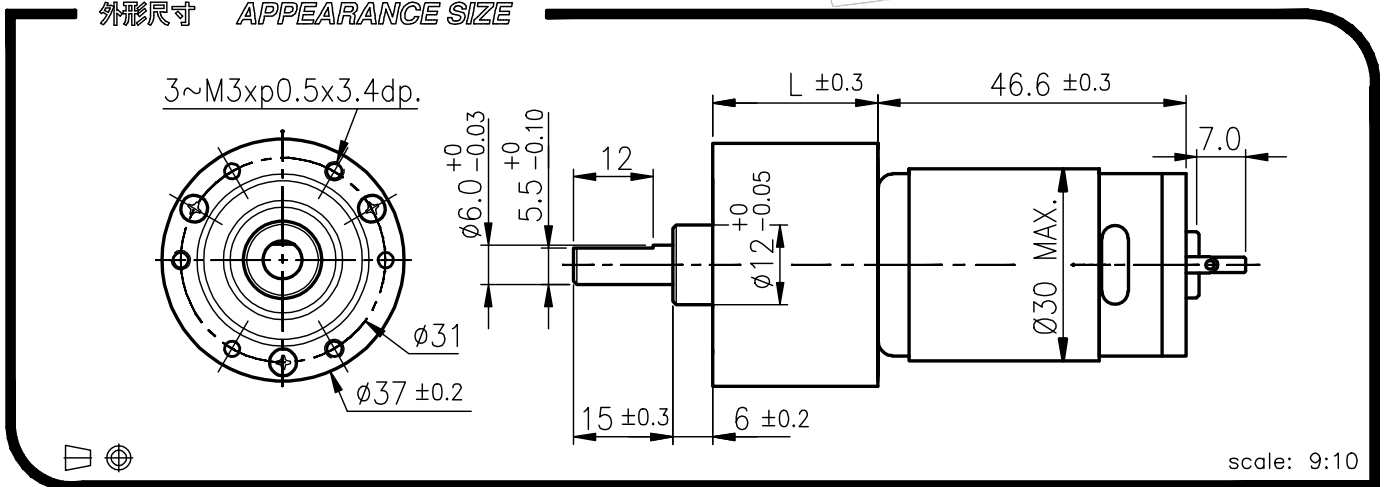

GEARED MOTOR TORQUE/SPEED

	減速比 Reduction ratio	1/6	1/16	1/21	1/31	1/56	1/75	1/104	1/125	1/156	1/188	1/219	1/250	1/312	1/469	1/625	1/750	1/938	1/1875	1/3750	1/5625
		12V	0.56	1.25	1.7	2.3	4.0	4.9	5.0	6.0	6.0	6.0	6.0	6.0	6.0	6.0	6.0	6.0	6.0	6.0	6.0
	定格回轉數 (rpm) Rated speed	952	381	286	191	106	79	58	47	38	32	27	23.8	19.1	12.7	9.5	7.9	6.3	3.2	1.6	1.1
24V	0.66	1.5	2.0	2.7	4.0	5.0	5.0	6.0	6.0	6.0	6.0	6.0	6.0	6.0	6.0	6.0	6.0	6.0	6.0	6.0	6.0
	定格回轉數 (rpm) Rated speed	986	394	296	197	112	83	60	49	39	33	28	24.6	19.7	13.1	9.9	8.2	6.6	3.3	1.6	1.1

馬達單體型式 / MOTOR DATA

定格電壓 Rated volt (V)	定格扭力 Rated torque (g-cm)	定格回轉數 Rated speed (rpm)	定格電流 Rated current (mA)	無負荷回轉數 No load speed (rpm)	無負荷電流 No load current (mA)	定格出力 Rated output (W)	重量 Weight (g)
12	110	5950	≤ 900	7300	≤ 150	7.0	110
24	130	6160	≤ 500	7300	≤ 80	8.5	110

馬達單體特性圖 / MOTOR CHARACTERISTICS

