

RB-30

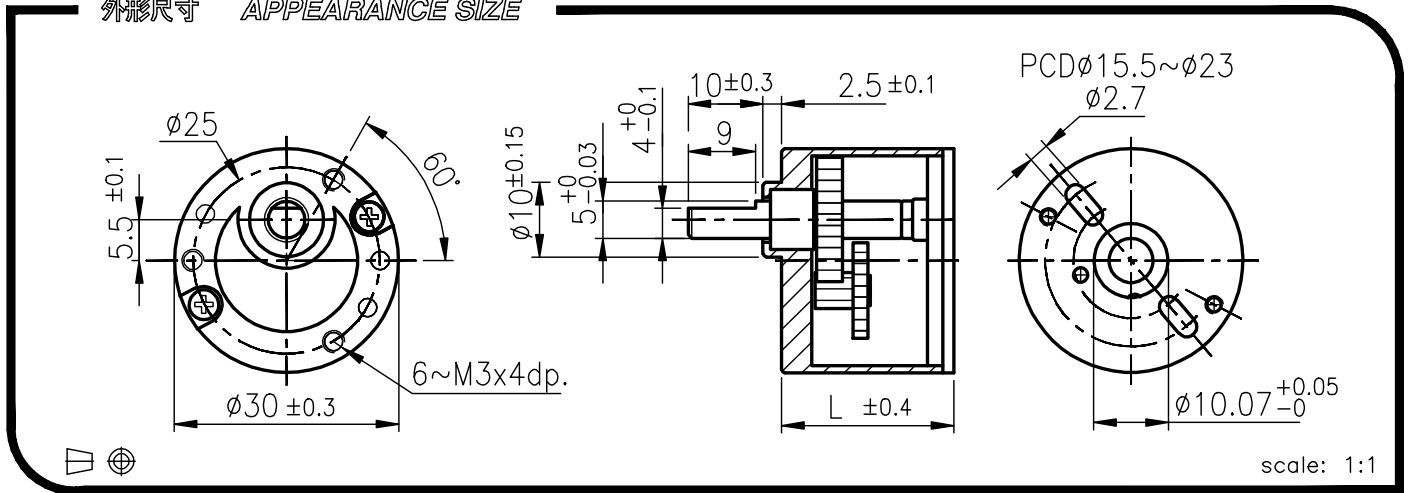

外殼材質 Housing material	金屬 metal	背隙 (無負荷時) Backlash, at no-load	≤ 2°
輸出軸承型式 Bearing at output	含油軸承 Sleeve bearings		
徑向負荷 Radial load (10mm from flange)	≤ 0.8 kgf		
軸向負荷 Shaft axial load	≤ 0.6 kgf		
主軸最大承受壓入力 Shaft press fit force, max.	≤ 10 kgf		
徑向間隙 Radial play of shaft	≤ 0.05 mm		
軸向間隙 Thrust play of shaft	≤ 0.35 mm		

外形尺寸 APPEARANCE SIZE



馬達齒輪型式 / PINION SPECIFICATIONS

模數 Module	0.4
齒數 No. of teeth	10
壓力角 Pressure angle	20°
孔徑 Hole diameter	ø1.98, ø2.28
減速比 Reduction ratio	全種通用 Practicable

馬達裝卸方法 / MOTOR INSTALLATION

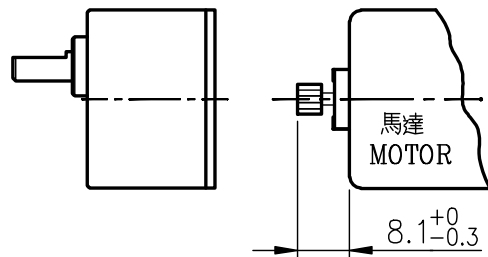

標準減速比型式 / GEARBOXES SPECIFICATIONS

★ 使用相對溼度: 20%~85%RH ★ 使用溫度範圍: -10°C~+60°C
Operating relative humidity Operating temperature range

減速比 Reduction ratio	定格容許扭力 Rated tolerance torque	瞬間容許扭力 Max momentary tolerance torque	效率 Efficiency	L	重量 Weight (g)
1/20	1.0 kgf-cm Max.	3.0 kgf-cm	66%	23.0	89
1/30, 1/36	1.5 kgf-cm Max.	4.5 kgf-cm	66%	23.0	89
1/50, 1/60	2.0 kgf-cm Max.	6.0 kgf-cm	66%	23.0	89
1/75, 1/90, 1/100	3.0 kgf-cm Max.	9.0 kgf-cm	66%	23.0	89
1/120, 1/150	4.0 kgf-cm Max.	12.0 kgf-cm	53%	28.0	98
1/180, 1/200	4.5 kgf-cm Max.	13.5 kgf-cm	53%	28.0	98
1/250, 1/300	4.5 kgf-cm Max.	13.5 kgf-cm	53%	28.0	98
1/400, 1/500, 1/600	4.5 kgf-cm Max.	13.5 kgf-cm	53%	28.0	98
1/810, 1/900, 1/1000	4.5 kgf-cm Max.	13.5 kgf-cm	53%	28.0	98

RB-30GM

02&03 TYPE



REDUCTION RATIO	L	REDUCTION RATIO	L
1/20~1/100	23.0	1/120~1/1000	28.0

外形尺寸 APPEARANCE SIZE

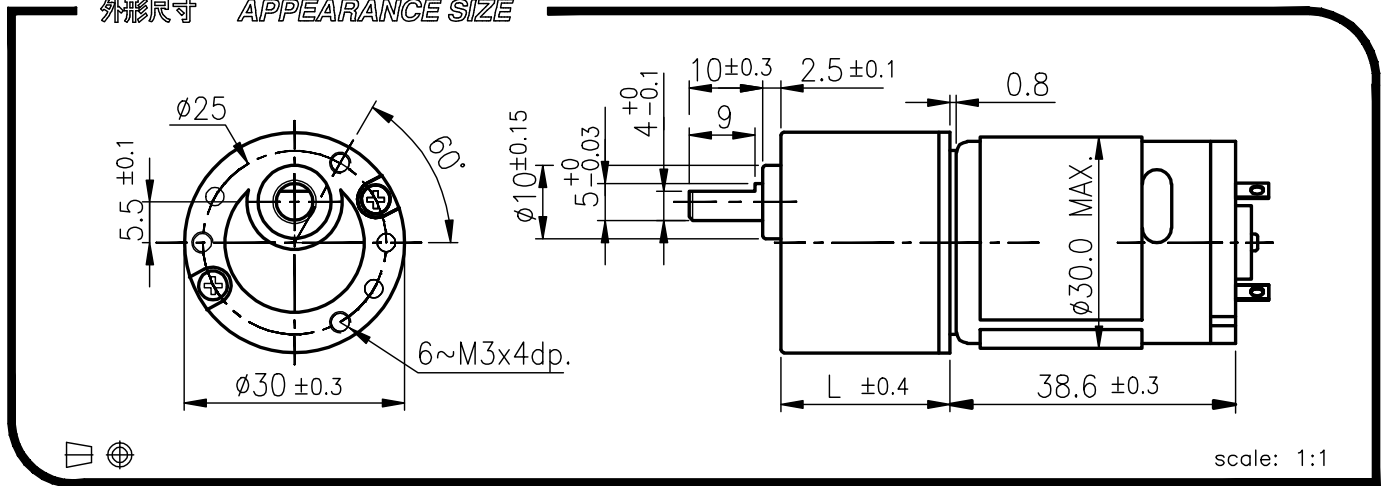

GEARED MOTOR TORQUE/SPEED

減速比 Reduction ratio		1/20	1/30	1/36	1/50	1/60	1/75	1/90	1/100	1/120	1/150	1/180	1/200	1/250	1/300	1/400	1/500	1/600	1/810	1/900	1/1000
12V	定格扭力(Kg-cm) Rated torque	1.0	1.5	1.5	2.0	2.0	3.0	3.0	3.0	4.0	4.0	4.5	4.5	4.5	4.5	4.5	4.5	4.5	4.5	4.5	4.5
	定格回轉數(rpm) Rated speed	255	168	150	107	91	73	62	56	46.3	37.5	32	28.8	24	19.5	15.2	12.1	10.4	7.7	6.9	6.3
24V	定格扭力(Kg-cm) Rated torque	1.0	1.5	1.5	2.0	2.0	3.0	3.0	3.0	4.0	4.0	4.5	4.5	4.5	4.5	4.5	4.5	4.5	4.5	4.5	4.5
	定格回轉數(rpm) Rated speed	258	168	150	107	91	73	62	56	46.3	37.4	31.8	28.7	24	19.5	15.1	12.1	10.3	7.7	6.9	6.3

馬達單體型式 / MOTOR DATA

定格電壓 Rated volt (V)	定格扭力 Rated torque (g-cm)	定格回轉數 Rated speed (rpm)	定格電流 Rated current (mA)	無負荷回轉數 No load speed (rpm)	無負荷電流 No load current (mA)	定格出力 Rated output (W)	重量 Weight (g)
12	78	5290	≤ 530	6500	≤ 150	4.22	73
24	74	5250	≤ 250	6500	≤ 85	3.97	73

馬達單體特性圖 / MOTOR CHARACTERISTICS

