

2相 57SHY 扁平式电机

57SHY电机是为金融终端客户量身定做的一款电机，产品的具有高频率运行特性，特殊的设计工艺保证电机厚度9.6mm，极大满足客户的要求。

照片

HYBRID STEPPING MOTOR 57SHY4001-2A

General specification		Electrical specification	
Step angle	1.8°	Rated voltage	2.8V
Number of phase	2	Rated current	0.8A
Insulation resistane	100MΩ min. (500V DC)	Resistance per phase	3.5Ω ±10%
Insulation class	Class B	Inductance per phase	1.8mH ±20%
Rotor inertia	15g.cm ²	Holding torque	60mN.m
Mass	75g	Detent torque	8mN.m

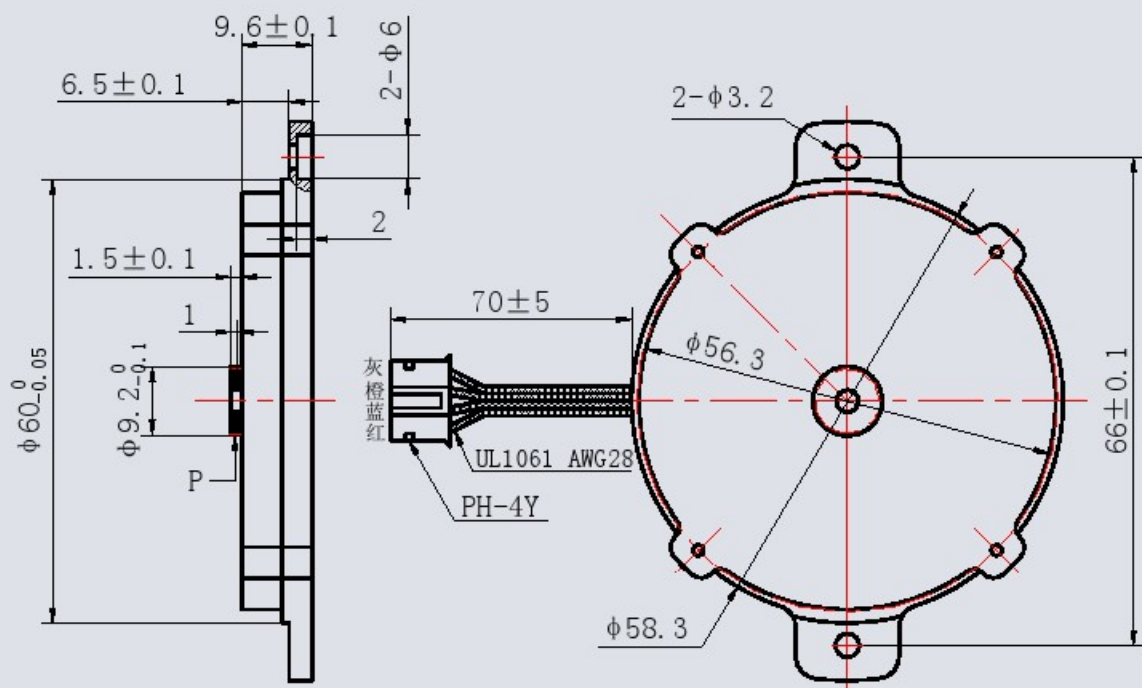

Wiring diagram

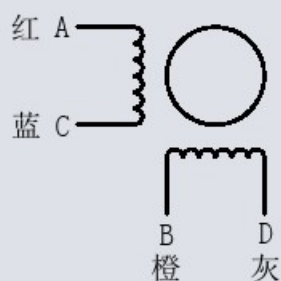

NOTE :