

# HYBRID STEPPING MOTOR B20SHD4401-01T3

General specification		Electrical specification	
Step angle	1.8°	Rated voltage	6.5V
Number of phase	2	Rated current	0.5A
Insulation resistane	100MΩmin. (500V DC)	Resistance per phase	13Ω ± 10%
Insulation class	Class B	Inductance per phase	4 (REF) mH ± 20%
Rotor inertia	4g. cm <sup>2</sup>	Holding torque	30mN. m
Mass	0.1kg	Detent torque	2mN. m
Resolution	0.0025mm	Thrust (full step)	7kg (at400pps, 24V)

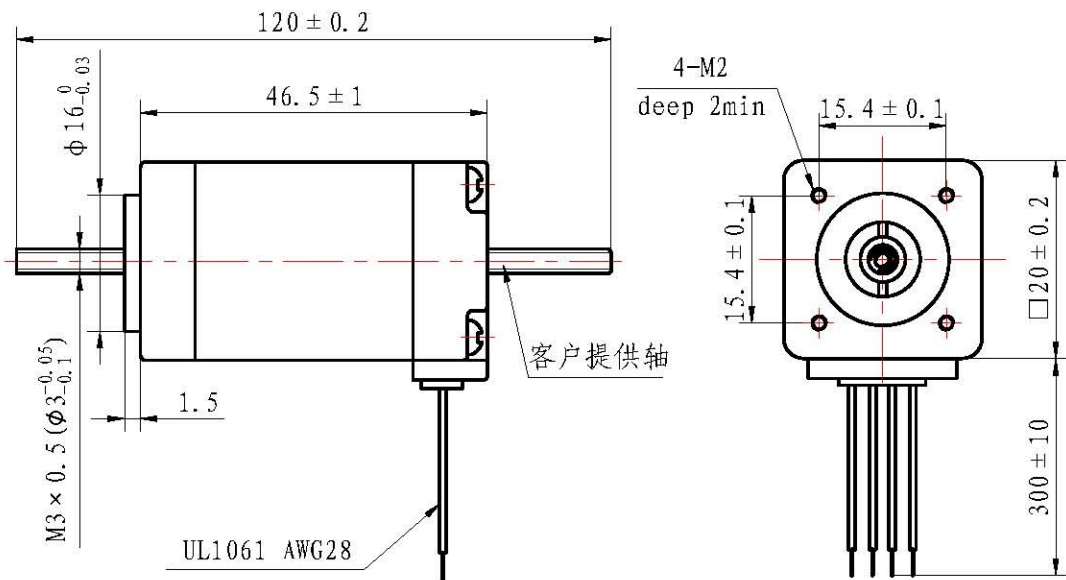

B20SHD4401-01T3

### Wiring diagram

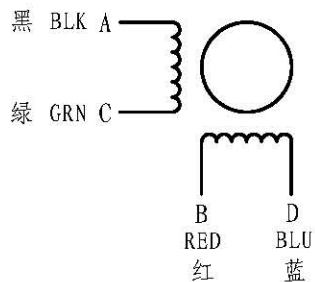

### 电机打标格式:

B20SHD4401-01T3  
YYYYMMDD RoHS

年月日

A0									
版本	更改内容	签字	日期	图样标记	重量	比例	B20SHD4401-01T3		
设计		标准化					FT3.162.		
审核		批准							
工艺		日期							
				共 1 张	第 1 张				